

## Linear Single Cell Li-Ion Battery Charger with Auto Power Path Management

### General Description

The RT9519A is an integrated single-cell Li-ion battery charger with auto power path management (APPM). No external MOSFETs are required. The RT9519A enters sleep mode when power is removed. Charging tasks are optimized by using a control algorithm to vary the charge rate, including pre-charge mode, fast charge mode and constant voltage mode. For the RT9519A, the charge current can also be programmed with an external resistor and modified with an external GPIO. The scope that the battery regulation voltage can be modified with an external GPIO depends on the battery temperature. The internal thermal feedback circuitry regulates the die temperature to optimize the charge rate for all ambient temperatures. The charging task will always be terminated in constant voltage mode when the charging current reduces to the termination current of 10% x ICHG\_FAST. Other features include under voltage protection and over voltage protection for VIN supply.

The recommended junction temperature range spans from -40°C to 125°C, while the ambient temperature range extends from -40°C to 85°C.

### Ordering Information

RT9519A□□

- Package Type  
QW : WQFN-20L 3x3 (W-Type)
- Lead Plating System  
G : Richtek Green Policy Compliant

Note:

Richtek products are Richtek Green Policy compliant and compatible with the current requirements of IPC/JEDEC J-STD-020.

### Marking Information

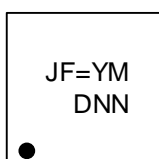

JF= : Product Code  
YMDNN : Date Code

### Features

- 28V Maximum Rating for VIN Power
- Selectable Power Current Limit (0.1A / 0.5A / 1.5A)
- Integrated Power MOSFETs
- Auto Power Path Management (APPM)
- Battery Charging Current Control
- Battery Regulation Voltage Control
- Programmable Charging Current and Safe Charge Timer
- Under Voltage Protection, Over Voltage Protection
- Power Good and Charge Status Indicator
- Optimized Charge Rate via Thermal Feedback
- Thin 20-Lead WQFN Package
- RoHS Compliant and Halogen Free

### Applications

- Digital Cameras
- PDAs and Smart Phones
- Portable Instruments

### Pin Configuration

(TOP VIEW)

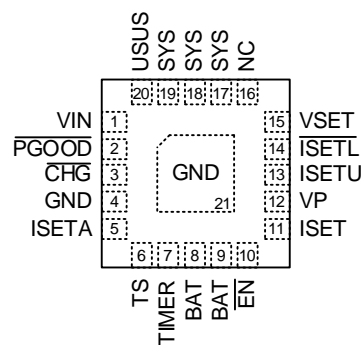

WQFN-20L 3x3



**Functional Pin Description**

Pin No.	Pin Name	Pin Function
1	VIN	Supply voltage input.
2	$\overline{\text{PGOOD}}$	Power good status output. Active low, open-drain output.
3	$\overline{\text{CHG}}$	Charger status output. Active low, open-drain output.
4, 21 (Exposed Pad)	GND	Ground. The exposed pad must be soldered to a large PCB and connected to GND for maximum power dissipation.
5	ISETA	Charge current set input. Connect a resistor ( $R_{\text{ISETA}}$ ) between ISETA and GND.
6	TS	Temperature Sense Input. The TS pin connects to a battery's thermistor to determine if the battery is too hot or too cold to charge. If the battery's temperature is out of range, charging is paused until it re-enters the valid range. TS also detect battery (with NTC) is present or not.
7	TIMER	Safe charge timer setting.
8, 9	BAT	Battery charge current output.
10	$\overline{\text{EN}}$	Charge enable. Active high input. 200k $\Omega$ pull low.
11	ISET	Half charge current set input. Control by external GPIO, L = ICHG1 / 2, H = ICHG1, 200k $\Omega$ pull low.
12	VP	This pin must be provided a regulated voltage from 2.95V to 3.6V by external power.
13	ISETU	VIN current limit control input. When $\overline{\text{ISETL}} = \text{H}$ , L = 100mA, H = 500mA, 200k $\Omega$ pull low.
14	$\overline{\text{ISETL}}$	VIN current limit control input. H : see ISETU, L = 1.5A, 200k $\Omega$ pull low.
15	VSET	Battery regulation set input. Control by external GPIO. L = 4.05V, H = 4.2V, 200k $\Omega$ pull low.
16	NC	No internal connection.
17, 18, 19	SYS	System connect pin. Connect this pin to system with a minimum 10 $\mu\text{F}$ ceramic capacitor connected to GND.
20	USUS	VIN suspend control input. H = Suspend, L = No suspend. 200k $\Omega$ pull low.

## Absolute Maximum Ratings (Note 1)

- Supply Voltage,  $V_{IN}$  ----- -0.3V to 28V
- $\overline{CHG}$ ,  $\overline{PGOOD}$  ----- -0.3V to 28V
- Other Pins ----- -0.3V to 6V
- $\overline{CHG}$ ,  $\overline{PGOOD}$  Continuous Current ----- 20mA
- BAT Continuous Current (total in two pins) (Note 2) ----- 2.5A
- Power Dissipation,  $P_D$  @  $T_A = 25^\circ\text{C}$   
 WQFN 20L 3x3 ----- 1.471W
- Package Thermal Resistance (Note 2)  
 WQFN 20L 3x3,  $\theta_{JA}$  -----  $68^\circ\text{C/W}$   
 WQFN 20L 3x3,  $\theta_{JC}$  -----  $7.5^\circ\text{C/W}$
- Lead Temperature (Soldering, 10sec.) -----  $260^\circ\text{C}$
- Junction Temperature -----  $150^\circ\text{C}$
- Storage Temperature Range -----  $-65^\circ\text{C}$  to  $150^\circ\text{C}$
- ESD Susceptibility (Note 3)  
 HBM (Human Body Model) ----- 2kV  
 MM (Machine Model) ----- 200V

## Recommended Operating Conditions (Note 4)

- Supply Input Voltage Range,  $V_{IN}$  ( $\overline{ISETL} = L$ ) ----- 4.4V to 6V
- Supply Input Voltage Range,  $V_{IN}$  ( $\overline{ISETL} = H$ ) ----- 4.5V to 6V
- Ambient Temperature Range -----  $-40^\circ\text{C}$  to  $85^\circ\text{C}$
- Junction Temperature Range -----  $-40^\circ\text{C}$  to  $125^\circ\text{C}$

## Electrical Characteristics

( $V_{IN} = 5\text{V}$ ,  $V_{BAT} = 4\text{V}$ ,  $T_A = 25^\circ\text{C}$ , unless otherwise specified)

Parameter	Symbol	Test Conditions	Min	Typ	Max	Unit
<b>Supply Input</b>						
VIN Under Voltage Lockout Threshold	$V_{UVLO}$	$V_{IN} = 0\text{V}$ to $4\text{V}$	3.1	3.3	3.5	V
VIN Under Voltage Lockout Hysteresis	$\Delta V_{UVLO}$	$V_{IN} = 4\text{V}$ to $0\text{V}$	--	240	--	mV
VIN Supply Current	$I_{SUPPLY}$	$I_{SYS} = I_{BAT} = 0\text{mA}$ , $\overline{EN} = L$ ( $V_{BAT} > V_{REGx}$ )	--	1	2	mA
		$I_{SYS} = I_{BAT} = 0\text{mA}$ , $\overline{EN} = H$ ( $V_{BAT} > V_{REGx}$ )	--	0.8	1.5	mA
VIN Suspend Current	$I_{USUS}$	$V_{IN} = 5\text{V}$ , $USUS = H$	--	195	300	$\mu\text{A}$
VBAT Sleep Leakage Current	$I_{SLEEP}$	$V_{BAT} > V_{IN}$ ( $V_{IN} = 0\text{V}$ )	--	5	15	$\mu\text{A}$
VIN-BAT VOS Rising	$V_{OS\_H}$		--	200	300	mV
VIN-BAT VOS Falling	$V_{OS\_L}$		10	50	--	mV

Parameter	Symbol	Test Conditions	Min	Typ	Max	Unit
<b>Voltage Regulation</b>						
System Regulation Voltage	V <sub>SYS</sub>	I <sub>SYS</sub> = 800mA	4.3	4.4	4.5	V
Battery Regulation Voltage	V <sub>REG1</sub>	Loading = 20mA When V <sub>SET</sub> = H	4.16	4.2	4.23	V
Battery Regulation Voltage	V <sub>REG2</sub>	Loading = 20mA When V <sub>SET</sub> = L	4.01	4.05	4.08	V
APPM Regulation Voltage	ΔV <sub>APPM</sub>	V <sub>SYS</sub> - ΔV <sub>APPM</sub>	120	200	280	mV
DPM Regulation Voltage	V <sub>DPM</sub>	I <sub>SETL</sub> = H	4.3	4.4	4.5	V
VIN to V <sub>SYS</sub> MOSFET Ron	R <sub>DS(ON)</sub>	I <sub>VIN</sub> = 1000mA	--	0.2	0.35	Ω
BAT to V <sub>SYS</sub> MOSFET Ron	R <sub>DS(ON)</sub>	V <sub>BAT</sub> = 4.2V, I <sub>SYS</sub> = 1A	--	0.05	0.1	Ω
Re-Charge Threshold	ΔV <sub>REGCHG</sub>	Battery Regulation – Recharge level	60	100	140	mV
<b>Current Regulation</b>						
ISETA Set Voltage (Fast Charge Phase)	V <sub>ISETA</sub>	V <sub>BAT</sub> = 4V, R <sub>ISETA</sub> = 1kΩ	--	2	--	V
VIN Charge Setting Range	I <sub>CHG</sub>		100	--	1200	mA
VIN Charge Current Accuracy1	I <sub>CHG1</sub>	V <sub>BAT</sub> = 4V, R <sub>ISETA</sub> = 1kΩ I <sub>SET</sub> = H	570	600	630	mA
VIN Charge Current Accuracy2	I <sub>CHG2</sub>	V <sub>BAT</sub> = 3.8V, R <sub>ISETA</sub> = 1kΩ I <sub>SET</sub> = L	285	300	315	mA
VIN Current Limit	I <sub>VIN</sub>	I <sub>SETL</sub> = L (1.5A Mode)	1	1.5	1.8	A
		I <sub>SETL</sub> = H, I <sub>SETU</sub> = H (500mA Mode)	430	475	500	mA
		I <sub>SETL</sub> = H, I <sub>SETU</sub> = L (100mA Mode)	70	95	100	mA
<b>Pre-Charge</b>						
BAT Pre-Charge Threshold	V <sub>PRECH</sub>	BAT Falling	2.7	2.8	2.9	V
BAT Pre-Charge Threshold Hysteresis	ΔV <sub>PRECH</sub>		--	200	--	mV
Pre-Charge Current	I <sub>CHG_PRE</sub>	V <sub>BAT</sub> = 2V	5	10	15	%
<b>Charge Termination Detection</b>						
Termination Current Ratio to Fast Charge (Except USB100 Mode)	I <sub>TERM</sub>	I <sub>SETL</sub> = H, I <sub>SETU</sub> = H I <sub>SETL</sub> = L, I <sub>SETU</sub> = X	5	10	15	%
Termination Current Ratio to Fast Charge (USB100 Mode)	I <sub>TERM2</sub>	I <sub>SETL</sub> = H, I <sub>SETU</sub> = L	--	3.3	--	%
<b>Login Input/Output</b>						
CHG Pull Down Voltage	V <sub>CHG</sub>	I <sub>CHG</sub> = 5mA	--	200	--	mV
PGOOD Pull Down Voltage	V <sub>PGOOD</sub>	I <sub>PGOOD</sub> = 5mA	--	200	--	mV
EN, I <sub>SETL</sub> , USUS, I <sub>SETU</sub> , V <sub>SET</sub> , I <sub>SET</sub> Threshold Voltage	Logic-High	V <sub>IH</sub>	1.5	--	--	V
	Logic-Low	V <sub>IL</sub>	--	--	0.4	

Parameter	Symbol	Test Conditions	Min	Typ	Max	Unit
<b>Protection</b>						
Thermal Regulation	T <sub>REG</sub>		--	125	--	°C
Thermal Shutdown Temperature	T <sub>SD</sub>		--	155	--	°C
Thermal Shutdown Hysteresis	ΔT <sub>SD</sub>		--	20	--	°C
Over Voltage Protection	V <sub>OVP</sub>	V <sub>IN</sub> Rising	6.25	6.5	6.75	V
Over Voltage Protection Hysteresis	ΔV <sub>OVP</sub>	V <sub>IN</sub> = 7V to 5V, V <sub>OVP</sub> – ΔV <sub>OVP</sub>	--	100	--	mV
Output Short Circuit Detection Threshold	V <sub>SHORT</sub>	V <sub>BAT</sub> –V <sub>SYS</sub>	--	300	--	mV
<b>Time</b>						
Pre-Charge Fault Time	t <sub>PCHG</sub>	C <sub>TIMER</sub> = 1μF (1/8 x t <sub>FCHG</sub> )	1440	1800	2160	s
Fast Charge Fault Time	t <sub>FCHG</sub>	C <sub>TIMER</sub> = 1μF	11520	14400	17280	s
$\overline{\text{PGOOD}}$ Deglitch Time	t <sub>PGOOD</sub>	Time measured from V <sub>IN</sub> : 0→5V 1μs rise time to $\overline{\text{PGOOD}}$ = L	--	1	--	s
Input Over Voltage Blanking Time	t <sub>OVP</sub>		--	50	--	μs
Pre-Charge to Fast-Charge Deglitch Time	t <sub>PF</sub>		--	25	--	ms
Fast-Charge to Pre-Charge Deglitch Time	t <sub>FP</sub>		--	25	--	ms
Termination Deglitch Time	t <sub>TERMI</sub>		--	25	--	ms
Recharge Deglitch Time	t <sub>RECHG</sub>		--	100	--	ms
Input Power Loss to SYS LDO Turn-Off Delay Time	t <sub>NO_IN</sub>		--	25	--	ms
Short Circuit ,Deglitch Time	t <sub>SHORT</sub>		--	250	--	μs
Short Circuit Recovery Time	t <sub>SHORT-R</sub>		--	64	--	ms
<b>Other</b>						
VP (External used only)	V <sub>VP</sub>		2.95	--	3.6	V
VP Under Voltage Lockout Threshold		Falling Threshold	--	0.8	--	V
TS Battery Detect Threshold	V <sub>TS</sub>		2.75	2.85	2.95	V
<b>NTC</b>						
Low Temperature Trip Point	V <sub>COLD</sub>	Rising Threshold	58.8	60	61.2	% of VP
Low Temperature Trip Point Hysteresis	ΔV <sub>COLD</sub>		--	1.5	--	% of VP
High Temperature Trip Point	V <sub>HOT</sub>	Falling Threshold	35.8	37.5	39.1	% of VP
High Temperature Trip Point Hysteresis	ΔV <sub>HOT</sub>		--	1.5	--	% of VP

**Note 1.** Stresses beyond those listed under “Absolute Maximum Ratings” June cause permanent damage to the device. These are stress ratings only, and functional operation of the device at these or any other conditions beyond those indicated in the operational sections of the specifications is not implied. Exposure to absolute maximum rating conditions June affect device reliability.

**Note 2.** Guaranteed by design.

**Note 3.**  $\theta_{JA}$  is measured under natural convection (still air) at  $T_A = 25^\circ\text{C}$  with the component mounted on a high effective-thermal-conductivity four-layer test board on a JEDEC 51-7 thermal measurement standard.  $\theta_{JC}$  is measured at the exposed pad of the package.

**Note 4.** Devices are ESD sensitive. Handling precautions are recommended.

**Note 5.** The device is not guaranteed to function outside its operating conditions.

## Typical Operating Characteristics

### Charger On/Off Control from $\overline{EN}$

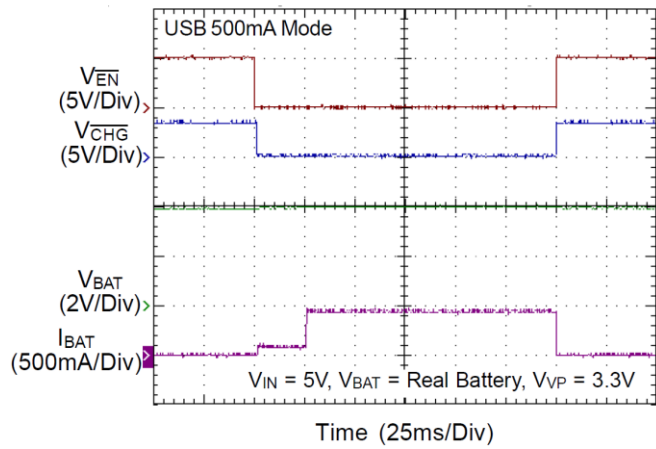

### Charger On/Off Control from $V_{IN}$

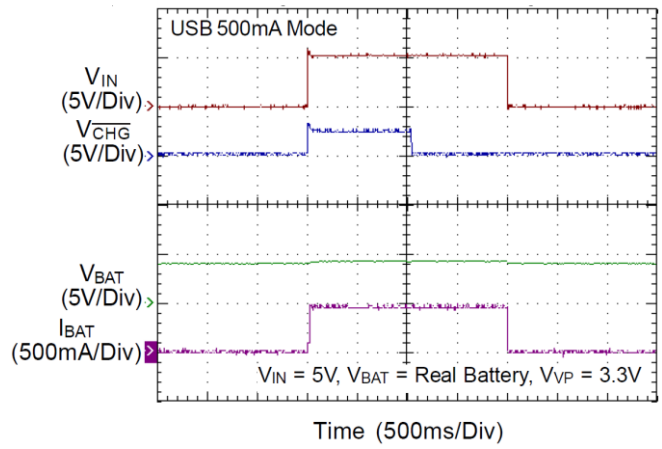

### TS Inserted/Removed

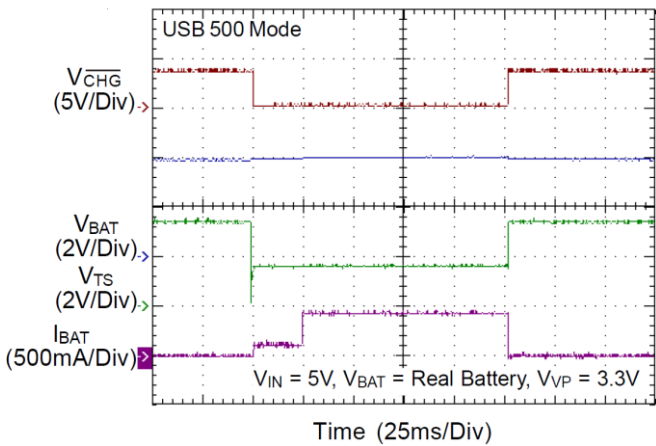

### $V_{IN}$ Removal

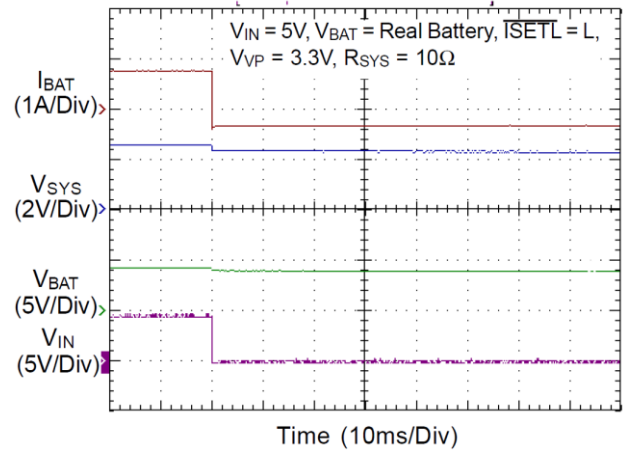

### $V_{IN}$ Hot-plug with NTC/Without Battery

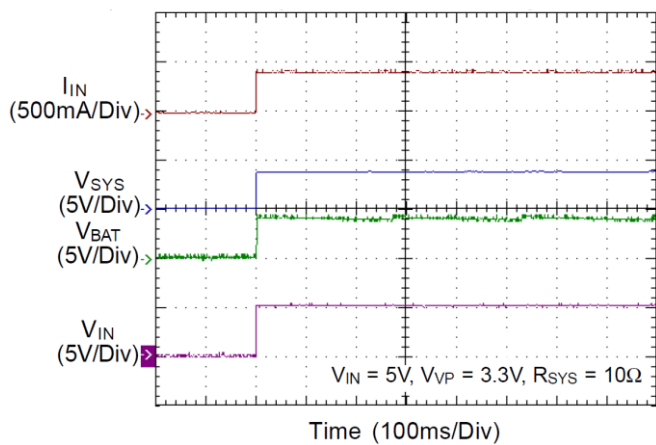

### $V_{IN}$ Hot-plug Without NTC/Battery

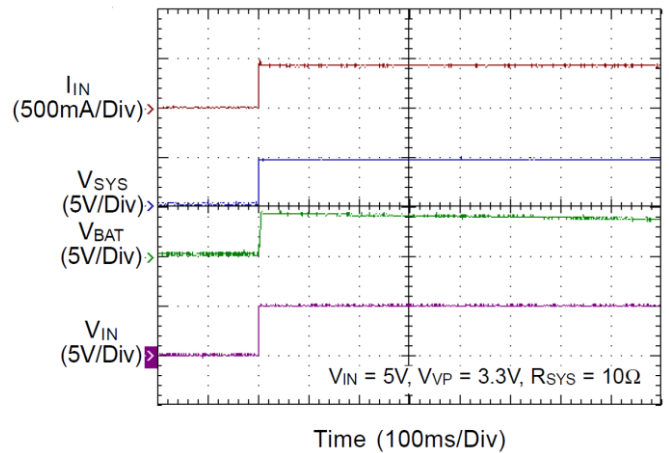



**V<sub>IN</sub> Hot-plug with Battery**

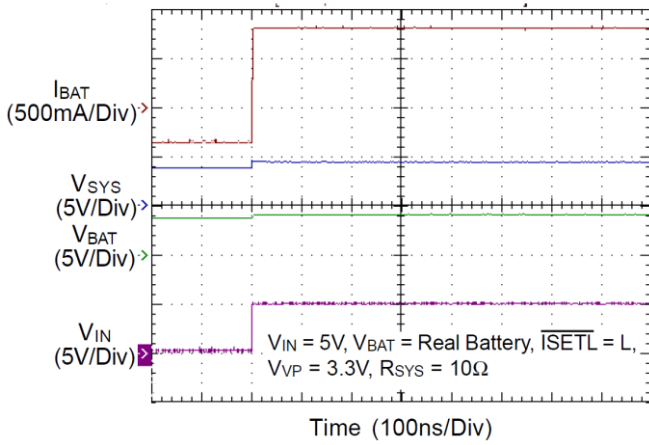

**System Regulation Voltage vs. Temperature**

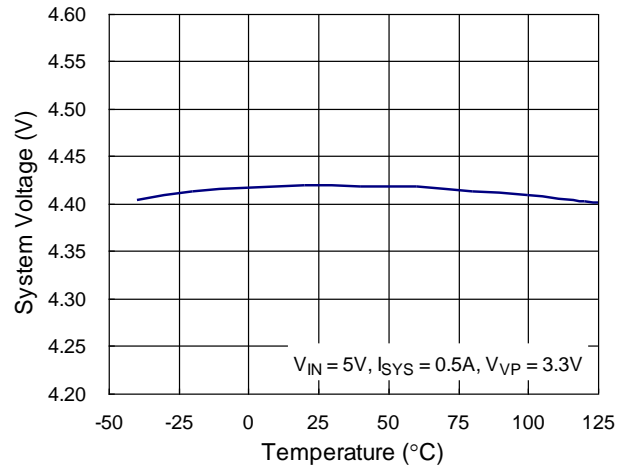

**V<sub>IN</sub> Over Voltage Protection**

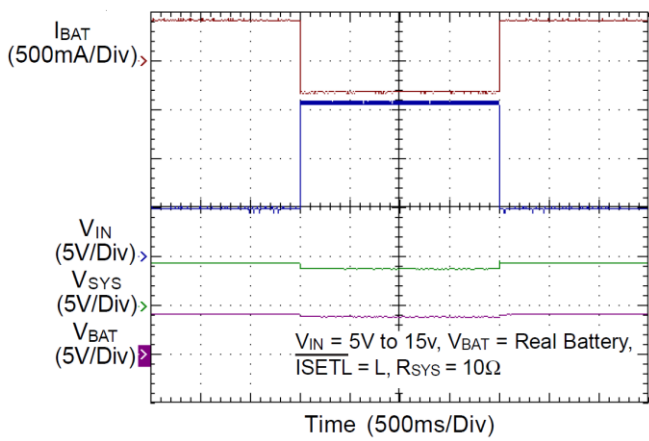

**OVP Threshold Voltage vs. Temperature**

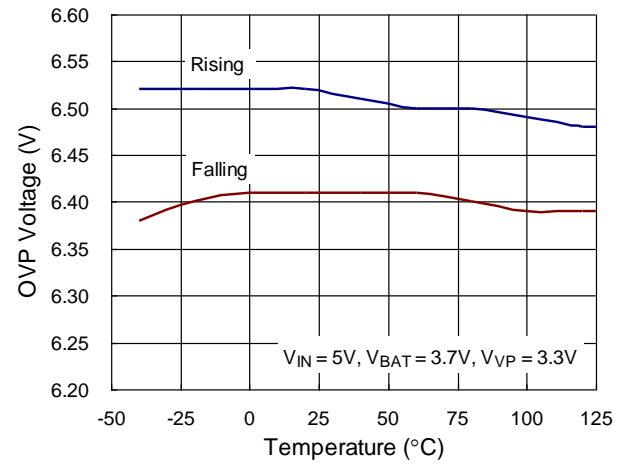

**V<sub>IN</sub> - V<sub>SYS</sub> Dropout Voltage vs. Temperature**

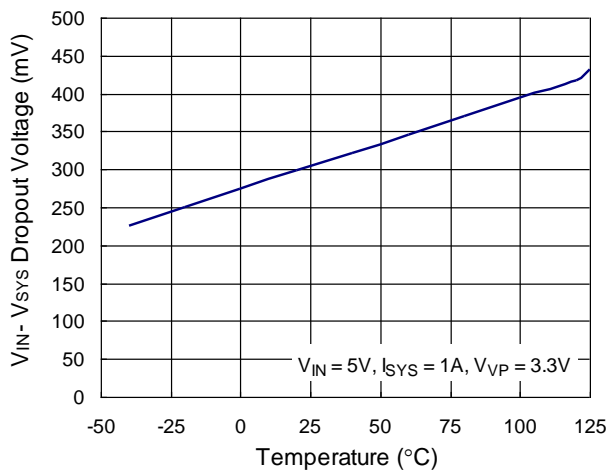

**V<sub>BAT</sub> - V<sub>SYS</sub> Dropout Voltage vs. Temperature**

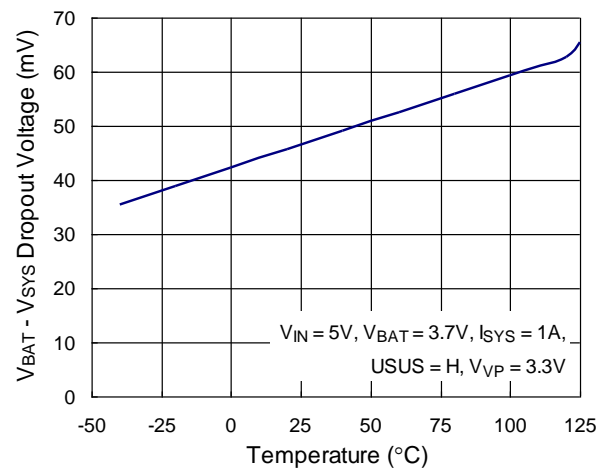

**I<sub>CHG</sub> Thermal Regulation vs. Temperature**

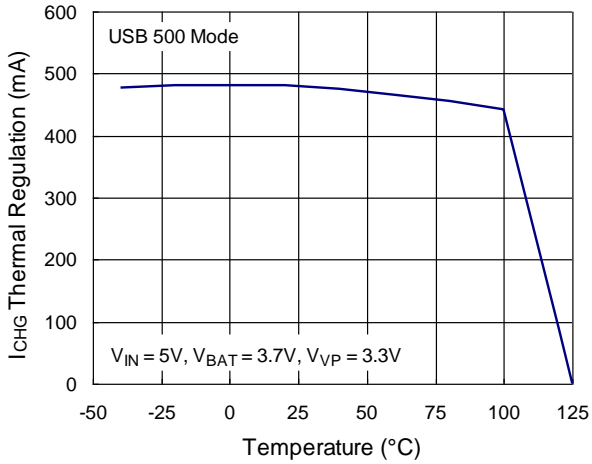

**Battery Regulation Voltage vs. Temperature**

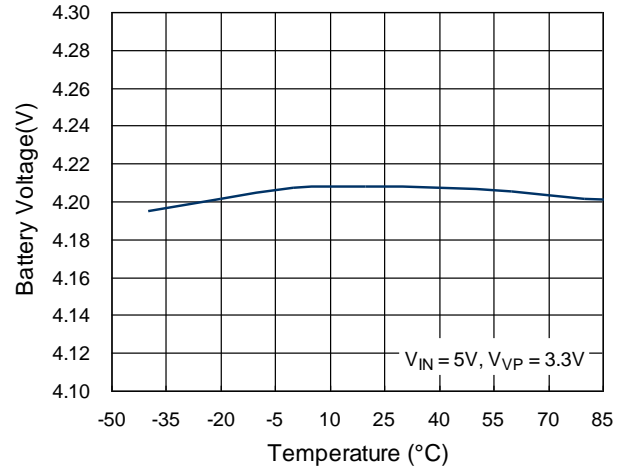

**Precharge Current vs. Battery Voltage**

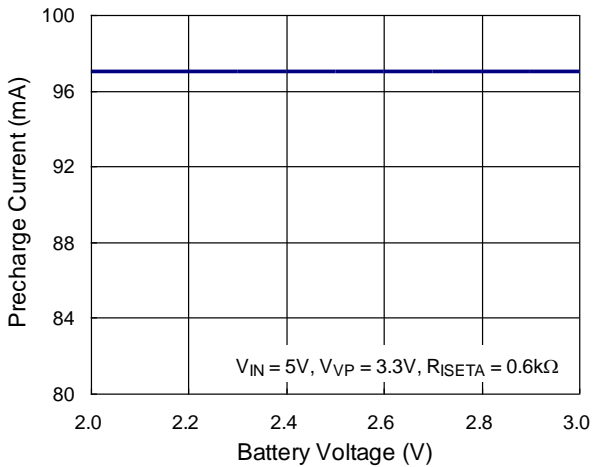

**Fastcharge Current vs. Battery Voltage**

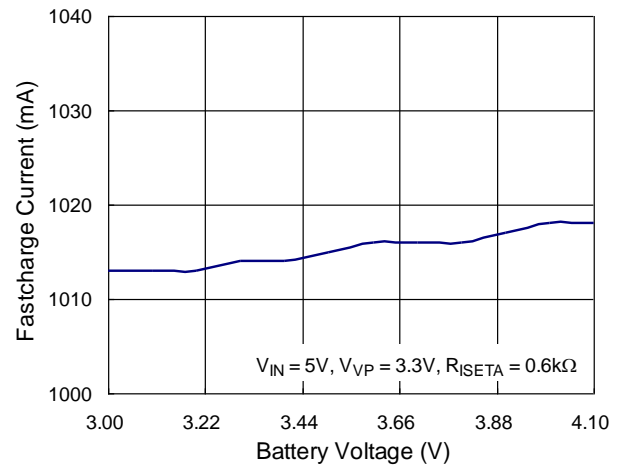

## Application Information

*Richtek's component specification does not include the following information in the Application Information section. Thereby no warranty is given regarding its validity and accuracy. Customers should take responsibility to verify their own designs and reserve suitable design margin to ensure the functional suitability of their components and systems.*

The RT9519A is a fully integrated single-cell Li-ion battery charger ideal for portable applications. The internal thermal feedback circuitry regulates the die temperature to optimize the charge rate for all ambient temperatures. Other features include under voltage protection and over voltage protection.

### Pre-charge Mode

When the output voltage is lower than 2.8V, the charging current will be reduced to a fast-charge current ratio set by RISETA to protect the battery life time.

### Fast-charge Mode

When the output voltage is higher than 3V, the charging current will be equal to the fast-charge current set by RISETA.

### Constant-Voltage Mode

When the output voltage is near 4.2V, and the charging current fall below the termination current, after a deglitch time check of 25ms, the charger will become disabled and CHG will go from L to H.

### Re-charge Mode

When the chip is in charge termination mode, the charging current will gradually go down to zero. However, once the voltage of the battery drops to below 4.1V, there will be a deglitch time of 100ms and then the charging current will resume again.

### Charging Current Decision

The charge current can be set according to the following equations :

If ISET = H (for ICHG1)

$$I_{CHG\_FAST} = \frac{V_{ISETA}}{R_{ISETA}} \times 300$$

If ISET = L (for ICHG2)

$$I_{CHG\_FAST} = \frac{V_{ISETA}}{R_{ISETA}} \times 150$$

$$I_{CHG\_PRE} = 10\% \times I_{CHG\_FAST}$$

### Time Fault

During the fast charge phase, several events may increase the charging time.

For example the system load current may have activated the APPM loop which reduces the available charging current, the device has entered thermal regulation because the IC junction temperature has exceeded TREG. During each of these events, if  $3V < V_{BAT} < 4.1V$ , the internal charging time is slowed down proportionately to the reduction in charging current. However, once the duration exceeds the fault time, the CHG output will flash at approximately 2Hz to indicate a fault condition and the charge current will be reduced to about 1mA.

$$t_{FCHG\_true} = t_{FCHG} \times \frac{2V}{V_{ISETA}}$$

tFCHG\_true : modified timer in fast

tFCHG : original timer in fast charger

$$t_{FCHG} = 14400 \times \left( \frac{C_{TIMER}}{1\mu F} \right)$$

$$t_{PCHG} = \frac{t_{FCHG}}{8}$$

tPCHG : timer in pre-charge

Time fault release methods :

- (1) Re-plug power
- (2) Toggle  $\overline{EN}$
- (3) Enter/exit suspend mode
- (4) Remove Battery
- (5) OVP

Note that the fast charge fault time is independent of the charge current.

### Power Good

VIN Power Good ( $\overline{PGOOD} = L$ )

Input State	$\overline{PGOOD}$ Output
$V_{IN} < V_{UVLO}$	High Impedance
$V_{UVLO} < V_{IN} < V_{BAT} + V_{OS\_H}$	High Impedance
$V_{BAT} + V_{OS\_H} < V_{IN} < V_{OVP}$	Low Impedance
$V_{IN} > V_{OVP}$	High Impedance

### Charge State Indicator

Charge State	$\overline{CHG}$ Output
Charging	Low (for first charge cycle)
Charging Suspended by Thermal Loop	
Safety Timers Expired	2Hz Flash
Charging Done	High Impedance
Recharging after Termination	
IC Disabled or no Valid Input Power	

### Battery Pack Temperature Monitoring

The battery pack temperature monitoring function can be realized by connecting the TS pin to an external Negative Temperature Coefficient (NTC) thermistor to prevent over temperature condition. Charging is suspended when the voltage at the TS pin is out of normal operating range. The internal timer is then paused, but the value is maintained. When the TS pin voltage returns back to normal operating range, charging will resume and the safe charge timer will continue to count down from the point where it was suspended. Note that although charging is suspended due to the battery pack temperature fault, the CHG pin will continue to remain low and indicate charging.

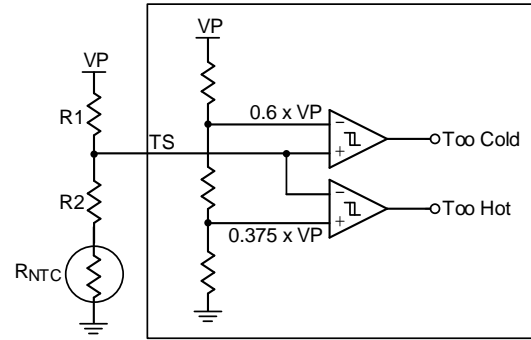

Figure 1

Too Cold Temperature

$$R_{COLD} = R_{NTC}$$

Too Hot Temperature

$$R_{HOT} = R_{NTC}$$

$$\frac{R_2 + R_{COLD}}{R_{COLD} + R_1 + R_2} = 0.6 \quad (1)$$

$$\frac{R_2 + R_{HOT}}{R_{HOT} + R_1 + R_2} = 0.375 \quad (2)$$

From (1), (2)

$$R_1 = \frac{R_{COLD} - R_{HOT}}{0.9}$$

$$R_2 = 0.6 \times R_1 - R_{HOT}$$

If  $R_2 < 0$

$$\frac{R_{COLD}}{R_{COLD} + R_1} = 0.6 \quad (3)$$

From (3)

$$R_1 = \frac{R_{COLD}}{0.6} - R_{COLD}$$

### Charge Enable

When  $\overline{EN}$  is High, the charger turns on. When  $\overline{EN}$  is low, the charger turns off.  $\overline{EN}$  is pulled low at the initial condition.

### VIN Input Current Limit

$\overline{ISETL}$	ISETU	VIN Input Current Limit
H	L	90mA
H	H	475mA
L	X	1.5A

## Suspend Mode

Set USUS = H, and the charge will enter Suspend Mode. In the Suspend Mode,  $\overline{\text{CHG}}$  is in high impedance and  $\text{IUSUS}(\text{MAX}) < 333\mu\text{A}$ .

## Power Switch

For the RT9519A, there are three power scenarios :

- (1) When a battery and an external power supply (USB or adapter) are connected simultaneously :

If the system load requirements exceed that of the input current limit, the battery will be used to supplement the current to the load. However, if the system load requirements are less than that of the input current limit, the excess power from the external power supply will be used to charge the battery.

- (2) When only the battery is connected to the system :  
The battery provides the power to the system.

- (3) When only an external power supply is connected to the system :

The external power supply provides the power to the system.

## Input DPM Mode

For the RT9519A, the input voltage is monitored when the USB100 or USB500 is selected. If the input voltage is lower than  $V_{\text{DPM}}$ , the input current limit will be reduced to stop the input voltage from dropping any further. This can prevent the IC from damaging improperly configured or inadequately designed USB sources.

## APPM Mode

Once the sum of the charging and system load currents becomes higher than the maximum input current limit, the SYS pin voltage will be reduced. When the SYS pin voltage is reduced to  $V_{\text{APPM}}$ , the RT9519A will automatically operate in APPM mode. In this mode, the charging current is reduced while the SYS current is increased to maintain system output. In APPM mode, the battery termination function is disabled.

## Battery Supplement Mode Short Circuit Protect

In APPM mode, the SYS voltage will continue to drop if the charge current is zero and the system load increases beyond the input current limit. When the SYS voltage decreases below the battery voltage, the battery will kick in to supplement the system load until the SYS voltage rises above the battery voltage.

While in supplement mode, there is no battery supplement current regulation. However, a built in short circuit protection feature is available to prevent any abnormal current situations. While the battery is supplementing the load, if the difference between the battery and SYS voltage becomes more than the short circuit threshold voltage, SYS will be disabled. After a short circuit recovery time,  $t_{\text{SHORT\_R}}$ , the counter will be restarted. In supplement mode, the battery termination function is disabled. Note that for the battery supply mode exit condition,  $V_{\text{BAT}} - V_{\text{SYS}} < 0\text{V}$ .

## Thermal Regulation and Thermal Shutdown

The RT9519A provides a thermal regulation loop function to monitor the device temperature. If the die temperature rises above the regulation temperature,  $T_{\text{REG}}$ , the charge current will automatically be reduced to lower the die temperature. However, in certain circumstances (such as high  $V_{\text{IN}}$ , heavy system load, etc.) even with the thermal loop in place, the die temperature may still continue to increase. In this case, if the temperature rises above the thermal shutdown threshold,  $T_{\text{SD}}$ , the internal switch between  $V_{\text{IN}}$  and SYS will be turned off. The switch between the battery and SYS will remain on, however, to allow continuous battery power to the load. Once the die temperature decreases by  $\Delta T_{\text{SD}}$ , the internal switch between  $V_{\text{IN}}$  and SYS will be turned on again and the device returns to normal thermal regulation.

## Charging Profile

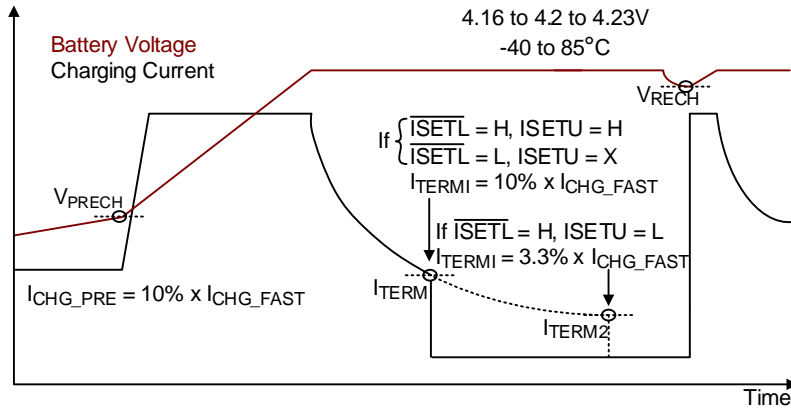

## APPM Profile

### 1.5A Mode :

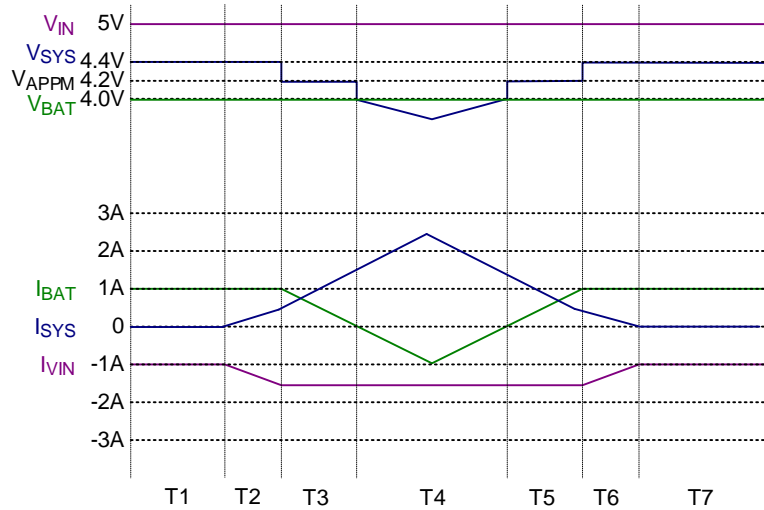

	$I_{SYS}$	$V_{SYS}$	$I_{VIN}$	$I_{BAT}$
T1, T7	0	SYS Regulation Voltage	CHG_MAX	CHG_MAX
T2, T6	$< I_{VIN\_OC} - CHG\_MAX$	SYS Regulation Voltage	$I_{SYS} + CHG\_MAX$	CHG_MAX
T3, T5	$> I_{VIN\_OC} - CHG\_MAX$ $< I_{VIN\_OC}$	Auto Charge Voltage Threshold	$V_{IN\_OC}$	$V_{IN\_OC} - I_{SYS}$
T4	$> I_{VIN\_OC}$	$V_{BAT} - I_{BAT} \times R_{DS(ON)}$	$V_{IN\_OC}$	$I_{SYS} - I_{VIN\_OC}$

## USB 500mA Mode :

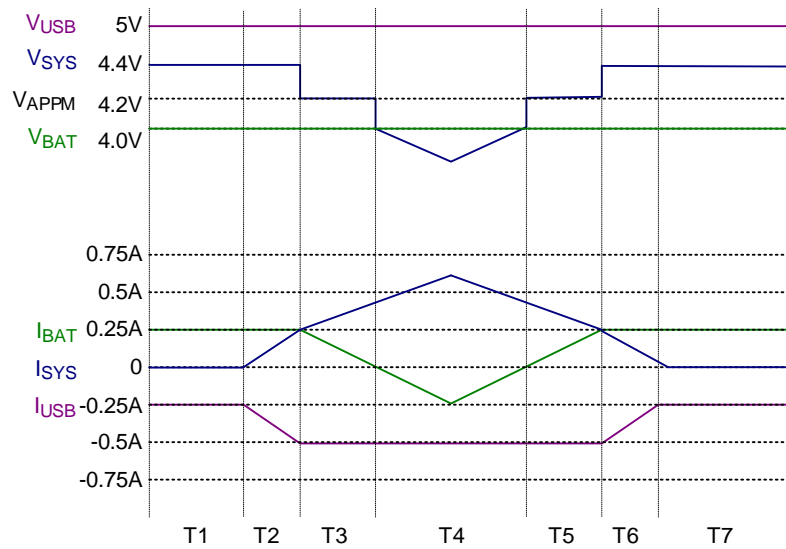

	<b>I<sub>sys</sub></b>	<b>V<sub>sys</sub></b>	<b>I<sub>usb</sub></b>	<b>I<sub>bat</sub></b>
T1, T7	0	SYS Regulation Voltage	CHG_MAX	CHG_MAX
T2, T6	< I <sub>VIN_OC</sub> (USB) - CHG_MAX	SYS Regulation Voltage	I <sub>sys</sub> + CHG_MAX	CHG_MAX
T3, T5	> I <sub>VIN_OC</sub> (USB) - CHG_MAX < I <sub>VIN_OC</sub> (USB)	Auto Charge Voltage Threshold	I <sub>VIN_OC</sub> (USB)	I <sub>VIN_OC</sub> (USB) - I <sub>sys</sub>
T4	> I <sub>VIN_OC</sub> (USB)	V <sub>BAT</sub> - I <sub>BAT</sub> x R <sub>DS(ON)</sub>	I <sub>VIN_OC</sub> (USB)	I <sub>sys</sub> - I <sub>VIN_OC</sub> (USB)

## VSET vs. VREG, ISET vs. ICHG

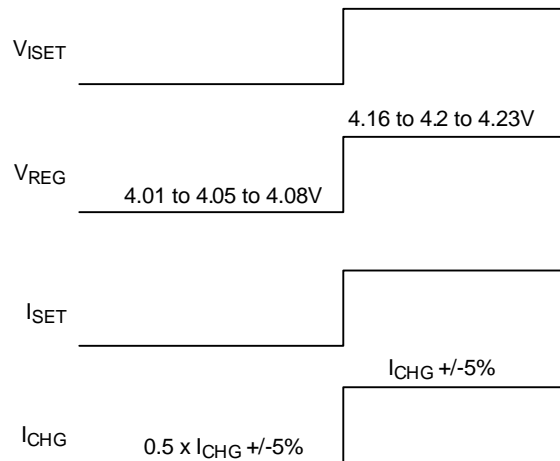

For JEITA Battery Temperature Standard :  
 CV regulation voltage will change at the following battery Temp ranges  
 0°C to 10°C and 45°C to 60°C  
 CC regulation current will change at the following battery Temp ranges  
 0°C to 10°C and 45°C to 60°C

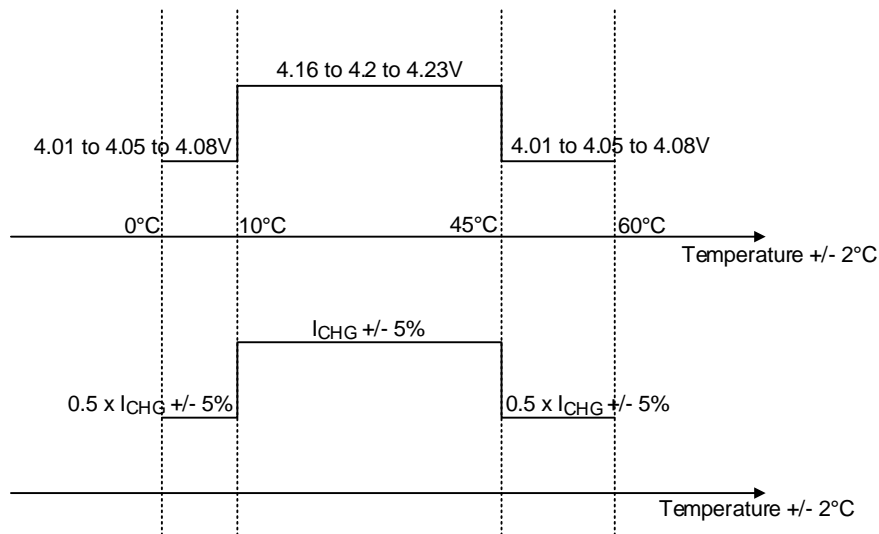



**RT9519A Operation State Diagram for Charging**

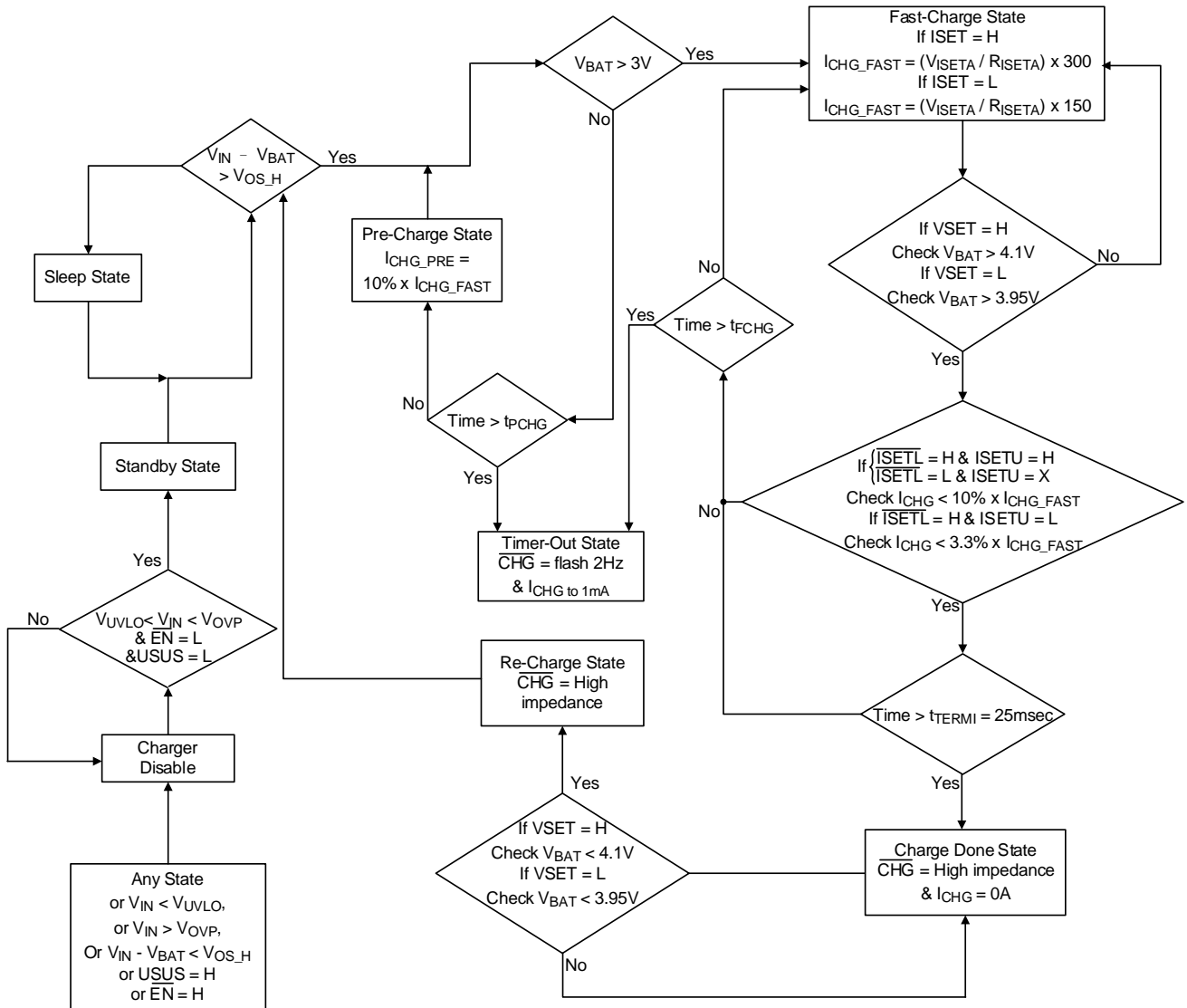

**Operation State Diagram for TS PIN**

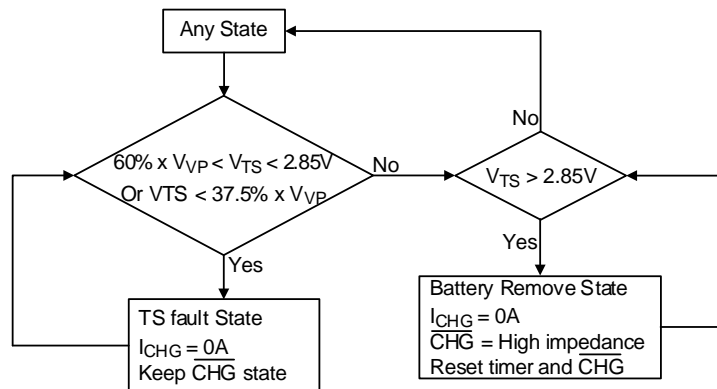

## Thermal Considerations

The junction temperature should never exceed the absolute maximum junction temperature  $T_{J(MAX)}$ , listed under Absolute Maximum Ratings, to avoid permanent damage to the device. The maximum allowable power dissipation depends on the thermal resistance of the IC package, the PCB layout, the rate of surrounding airflow, and the difference between the junction and ambient temperatures. The maximum power dissipation can be calculated using the following formula :

$$P_{D(MAX)} = (T_{J(MAX)} - T_A) / \theta_{JA}$$

where  $T_{J(MAX)}$  is the maximum junction temperature,  $T_A$  is the ambient temperature, and  $\theta_{JA}$  is the junction-to-ambient thermal resistance.

For continuous operation, the maximum operating junction temperature indicated under Recommended Operating Conditions is 125°C. The junction-to-ambient thermal resistance,  $\theta_{JA}$ , is highly package dependent. For a WQFN-20L 3x3 package, the thermal resistance,  $\theta_{JA}$ , is 68°C/W on a standard JEDEC 51-7 high effective-thermal-conductivity four-layer test board. The maximum power dissipation at  $T_A = 25^\circ\text{C}$  can be calculated as below :

$$P_{D(MAX)} = (125^\circ\text{C} - 25^\circ\text{C}) / (68^\circ\text{C}/\text{W}) = 1.471\text{W for a WQFN-20L 3x3 package.}$$

The maximum power dissipation depends on the operating ambient temperature for the fixed  $T_{J(MAX)}$  and the thermal resistance,  $\theta_{JA}$ . The derating curves in Figure 2 allows the designer to see the effect of rising ambient temperature on the maximum power dissipation.

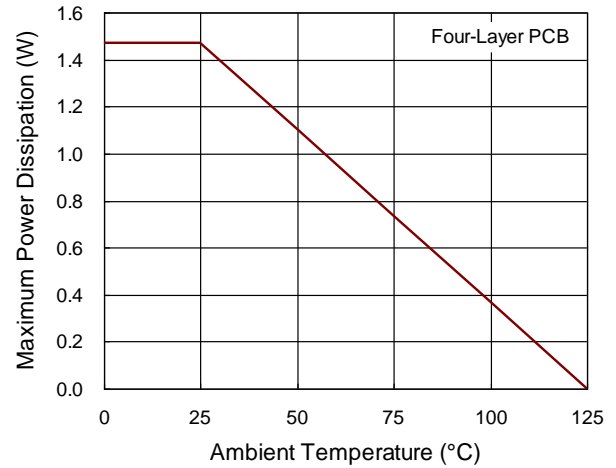
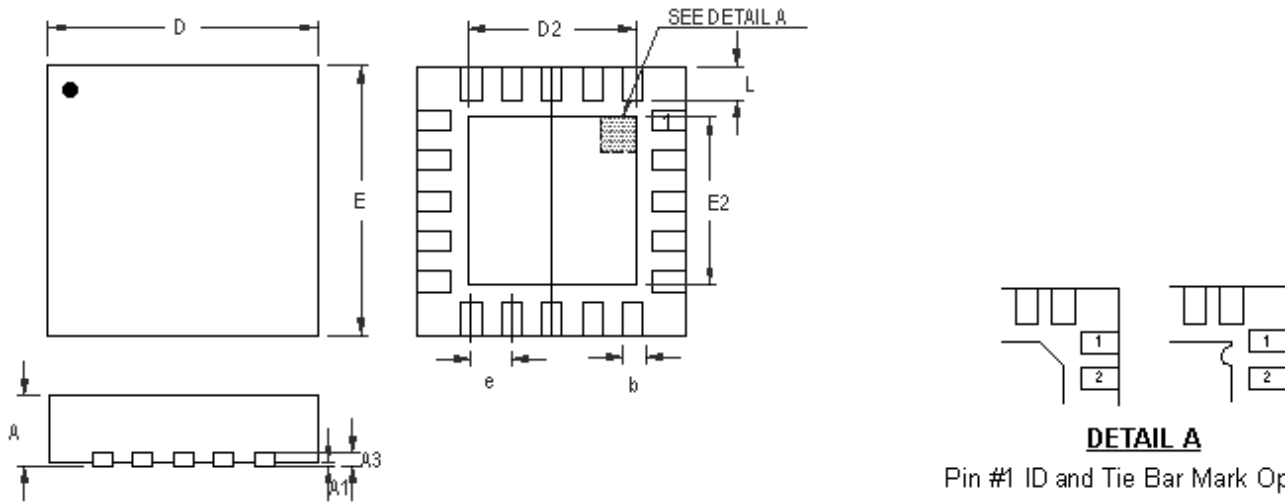

Figure 2. Derating Curves for RT9519A Package

**Outline Dimension**



**DETAIL A**  
Pin #1 ID and Tie Bar Mark Options

Note : The configuration of the Pin #1 identifier is optional, but must be located within the zone indicated.

Symbol	Dimensions In Millimeters		Dimensions In Inches	
	Min	Max	Min	Max
A	0.700	0.800	0.028	0.031
A1	0.000	0.050	0.000	0.002
A3	0.175	0.250	0.007	0.010
b	0.150	0.250	0.006	0.010
D	2.900	3.100	0.114	0.122
D2	1.650	1.750	0.065	0.069
E	2.900	3.100	0.114	0.122
E2	1.650	1.750	0.065	0.069
e	0.400		0.016	
L	0.350	0.450	0.014	0.018

**W-Type 20L QFN 3x3 Package**

## Footprint Information

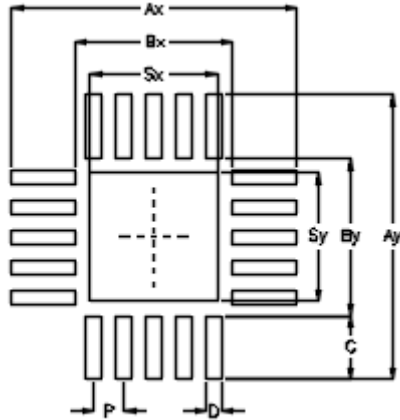

Package	Number of Pin	Footprint Dimension (mm)									Tolerance
		P	Ax	Ay	Bx	By	C	D	Sx	Sy	
V/W/U/XQFN3*3-20	20	0.40	3.80	3.80	2.10	2.10	0.85	0.20	1.70	1.70	±0.05

**Packing Information**

**Tape and Reel Data**

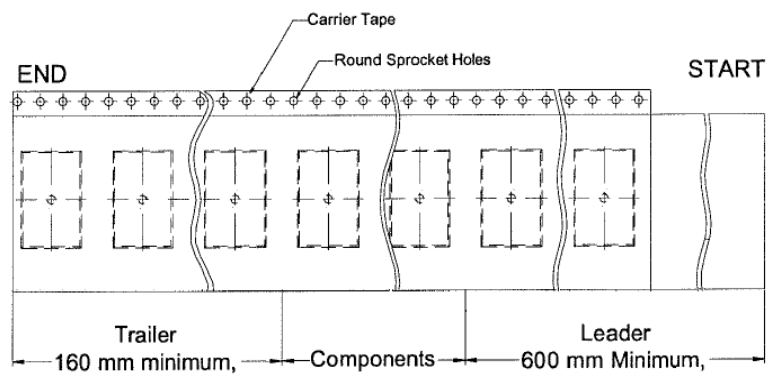
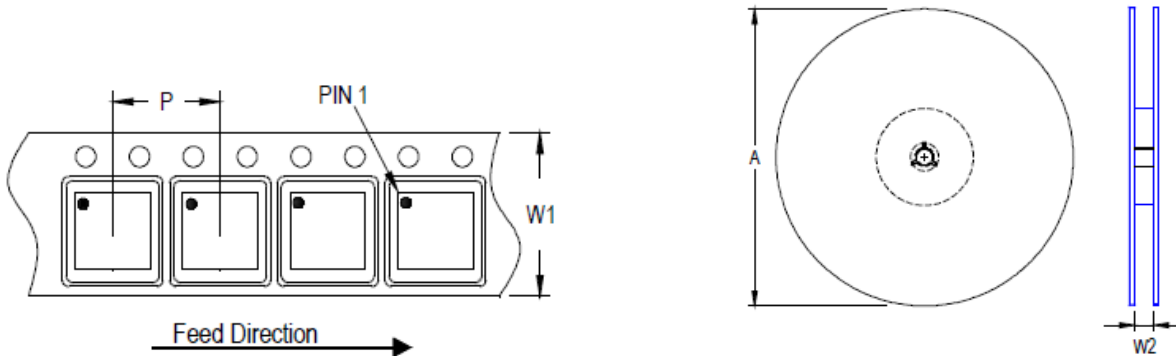



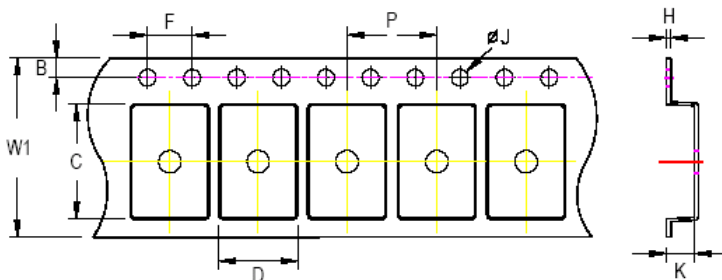

Package Type	Tape Size (W1) (mm)	Pocket Pitch (P) (mm)	Reel Size (A)		Units per Reel	Trailer (mm)	Leader (mm)	Reel Width (W2) Min./Max. (mm)
			(mm)	(in)				
QFN/DFN 3x3	12	8	180	7	1,500	160	600	12.4/14.4



**C, D and K are determined by component size.**  
**The clearance between the components and the cavity is as follows:**  
**- For 12mm carrier tape: 0.5mm max.**

Tape Size	W1		P		B		F		ØJ		H
	Max.	Min.	Max.	Min.	Max.	Min.	Max.	Min.	Max.	Max.	
12mm	12.3mm	7.9mm	8.1mm	1.65mm	1.85mm	3.9mm	4.1mm	1.5mm	1.6mm	0.6mm	

## Tape and Reel Packing

Step	Photo/Description	Step	Photo/Description
1	 <p>Reel 7"</p>	4	 <p>3 reels per inner box <b>Box A</b></p>
2	 <p>HIC &amp; Desiccant (1 Unit) inside</p>	5	 <p>12 inner boxes per outer box</p>
3	 <p>Caution label is on backside of Al bag</p>	6	 <p>Outer box <b>Carton A</b></p>

Package	Container		Reel				Box				Carton			
	Size	Units	Item	Size(cm)	Reels	Units	Item	Size(cm)	Boxes	Unit				
QFN & DFN 3x3	7"	1,500	Box A	18.3*18.3*8.0	3	4,500	Carton A	38.3*27.2*38.3	12	54,000				
			Box E	18.6*18.6*3.5	1	1,500	For Combined or Partial Reel.							

**Packing Material Anti-ESD Property**

Surface Resistance	Aluminum Bag	Reel	Cover tape	Carrier tape	Tube	Protection Band
$\Omega/\text{cm}^2$	$10^4$ to $10^{11}$	$10^4$ to $10^{11}$	$10^4$ to $10^{11}$	$10^4$ to $10^{11}$	$10^4$ to $10^{11}$	$10^4$ to $10^{11}$

**Richtek Technology Corporation**

14F, No. 8, Tai Yuen 1<sup>st</sup> Street, Chupei City  
 Hsinchu, Taiwan, R.O.C.  
 Tel: (8863)5526789

**RICHTEK**

Richtek products are sold by description only. Richtek reserves the right to change the circuitry and/or specifications without notice at any time. Customers should obtain the latest relevant information and data sheets before placing orders and should verify that such information is current and complete. Richtek cannot assume responsibility for use of any circuitry other than circuitry entirely embodied in a Richtek product. Information furnished by Richtek is believed to be accurate and reliable. However, no responsibility is assumed by Richtek or its subsidiaries for its use; nor for any infringements of patents or other rights of third parties which may result from its use. No license is granted by implication or otherwise under any patent or patent rights of Richtek or its subsidiaries.

## Datasheet Revision History

Version	Date	Description	Item
03	2022/11/23	Modify	Electrical Characteristics on P5 Application Information on P11 Footprint Information on P20 Packing Information on P21, 22, 23
04	2023/10/2	Modify	General Description on P1 Ordering Information on P1 Electrical Characteristics on P5 Application Information on P11